

50DS Single Axle Low Profile Dump

| | | | |
|----------------------------|---|----------------------|---|
| G.V.W.R. | 5,000# | AXLE | 5,200# EZ Lube w/Elec. Brakes |
| G.A.W.R. (Ea. Axle) | 5,080# | SUSPENSION | Multi-Leaf Spring |
| COUPLER | 7K 2" Forged A-Frame | TIRE | ST225/75-15 Load Range D |
| SAFETY CHAINS | 1/4" Grd. 70 w/Safety Latch Hook (2 each) | WHEEL | 15 x 6 White Spoke 6 Bolt |
| JACKS | 2,000# Top Wind (Bolted On) | FLOOR | 12 Gauge Smooth Steel |
| TONGUE | 5" Channel | LIGHTS | D.O.T. Stop, Tail, Turn & Clearance |
| FRAME | 5" Channel | ELEC. PLUG | 7-Way RV |
| CROSSMEMBERS | 3" X 3" Square Tubing | FINISH (Prep) | Steel is Cleaned and Etched to Ensure Smooth, High Bond Paint Adhesion. |
| BED CROSSMEMBERS | 2" x 2" Square Tubing | FINISH | Painted with High-Solids Supreme Automotive Grade Enamel and Pin-Striped for a Highly Decorative and Protective Finish. |
| BED LONG SILS | 3" Channel | | |
| BED SIDE RAILS | 5" x 3" Formed Angle | | |
| FENDERS | 9" x 36" Radius' D | | |

Standard Features

- Safety Chains Attached w/Cold Rolled Eyelets
- Enclosed Pump & Battery Box Mounted in Front of Bed
- Lockable Control Unit
- 18", 12 Ga. Sides w/Formed Channel Supports
- 1 Piece 12 Ga. Floor
- 1/2" Tie Rail on all 4 Sides
- Stake Pockets (Sides & Front)
- Self Contained Electric/Hydraulic Scissor Lift
- 45 Degree Dump Angle
- Cambered EZ Lube Axle
- Complete Break-A-Way System w/Charge Line
- Grommet Mount Sealed Lighting
- 1 Piece 2 Way Style Rear Gate

| Dimensions | | | |
|------------|------|-----|-----|
| Length | A | B | C |
| 10' | 120" | 54" | 66" |

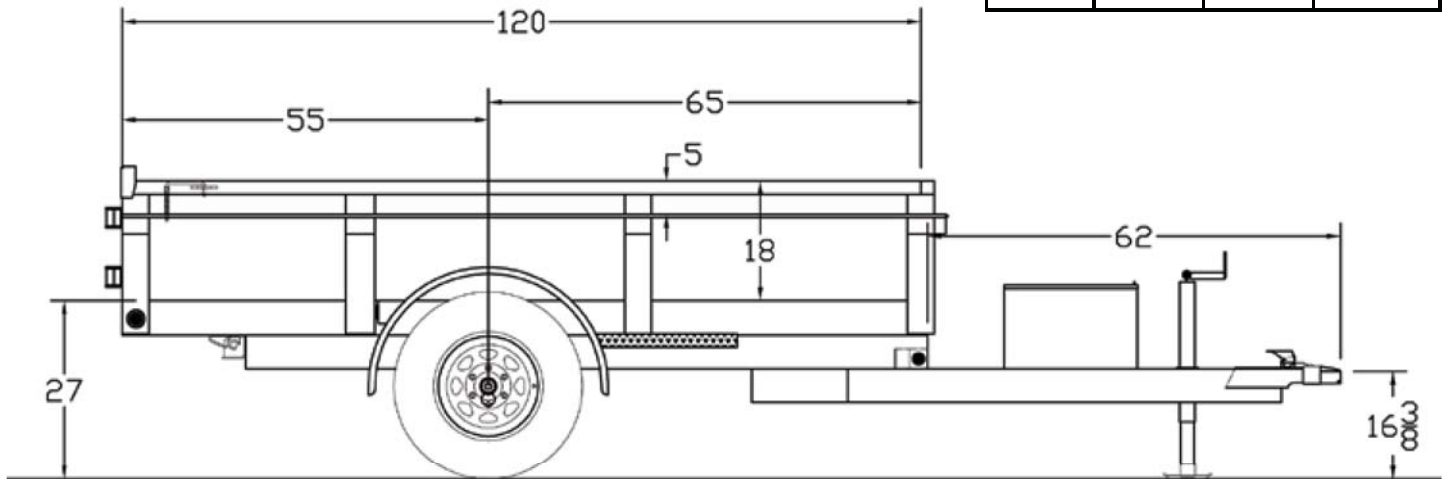

| MODEL# | DESCRIPTION |
|---------|--|
| 50DS-10 | 60" x 10' Low Profile Single Axle Dump |

TRAILER WEIGHTS & CAPACITIES

| LENGTH | EMPTY WEIGHT | PAYLOAD | BOX CAPACITY |
|--------|--------------|---------|-----------------|
| 10' | 1,850# | 3,150# | 2.5 Cubic Yards |

OPTIONS

| | |
|-------------------------------|-----------------------|
| Hydraulic Surge Brake | 2 Watt Solar Charger |
| Spare Tire Mount | 5 Watt Solar Charger |
| Spare Tire (ST225/75-15 LR-D) | 110V Charger |
| Wireless Remote | Crank Style Roll Tarp |