

45LA Tandem Axle Utility

G.V.W.R.	4,500#	AXLES	Two 3,500# EZ Lube w/1 Elec. Brake
G.A.W.R. (Ea. Axle)	3,500#	SUSPENSION	Multi-Leaf Spring
COUPLER	2" A-Frame	TIRE	ST205/75-15 Load Range C
SAFETY CHAINS	1/4" Grd. 30 w/Safety Latch Hook (2 each)	WHEEL	15 x 5 White Spoke 5 Bolt
JACK	2,000# Top Wind (Bolted On)	FLOOR	2" Pine
TONGUE	4" Channel	LIGHTS	D.O.T. Stop, Tail, Turn & Clearance
TOP RAIL	3" x 2" x 3/16" Angle	ELEC. PLUG	7-Way RV
FRAME	3" x 2" x 3/16" Angle	FINISH (Prep)	Steel is Cleaned and Etched to Ensure Smooth, High Bond Paint Adhesion.
CROSSMEMBERS	3" x 2" x 3/16" Angle	FINISH	Painted with High-Solids Supreme Automotive Grade Enamel and Pin-Striped for a Highly Decorative and Protective Finish.
UPRIGHTS	14" Tall, 2" x 2" x 1/8" Angle		
FENDERS	9" x 72" Rolled Formed w/Back		

Standard Features

- Safety Chains Attached w/Cold Rolled Eyelets
- Sand Foot on Jack
- Lower Jack Support Plate
- Floor Secured w/Torx Screws
- 4 Tie Down Loops
- EZ Lube Axles
- 3,500# Axles w/1 Electric Brake
- Complete Break-A-Way System w/Charger
- Grommet Mount Sealed Lighting

Dimensions			
Length	A	B	C
10'	121-1/2"	73"	48-1/2"
12'	145-1/2"	85"	60-1/2"
14'	169-1/2"	103"	66-1/2"

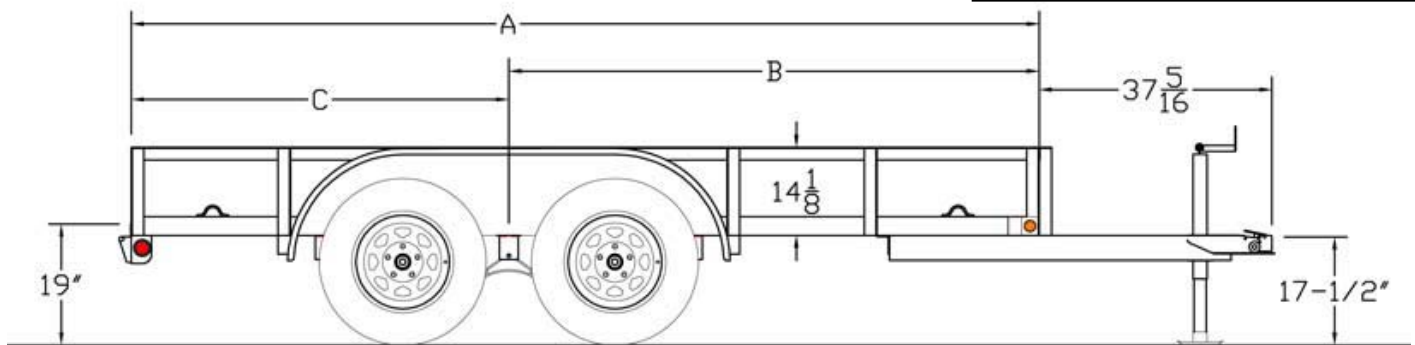

MODEL#	WEIGHT	DESCRIPTION
45LA-10	1,110#	60" x 10' Tandem Axle Trailer
45LA-12	1,190#	60" x 12' Tandem Axle Trailer
45LA-14	1,370#	60" x 14' Tandem Axle Trailer

OPTIONS

2" Forged Coupler	Spare Tire Mount (Side)
2-5/16" Stamped Coupler	Spare Tire (ST205/75-15 LR-C)
2-5/16" Forged Coupler	4' Rampgate (5 W)
2K Fold-Up Jack	Gas Spring Assist Option - Rampgate
Electric Brakes on 2nd Axle	Tie Down Pockets (Each)
Hydraulic Brakes 1 Axle w/Atwood Actuator	Heavy Duty Frame
Hydraulic Brakes 2 Axles w/ Atwood Actuator	

STANDARD MODEL - NO OTHER OPTIONS AVAILABLE