

40SP Tandem Axle Utility

G.V.W.R.	4,000#	AXLES	Two 3,500# EZ Lube w/1 Elec. Brake
G.A.W.R. (Ea. Axle)	2,960#	SUSPENSION	Multi-Leaf Spring w/Equalizer
COUPLER	2" A-Frame	TIRE	ST205/75-15 Load Range B
SAFETY CHAINS	1/4" Grd. 30 w/Safety Latch Hook (2 each)	WHEEL	15 x 5 White Spoke 5 Bolt
JACK	2,000# Top Wind (Bolted On)	FLOOR	2" Pine
TONGUE	4" Channel	LIGHTS	D.O.T. Stop, Tail, Turn & Clearance
TOP RAIL	2" x 2" x 1/8" Angle	ELEC. PLUG	7-Way RV
FRAME	3" x 2" x 3/16" Angle	FINISH (Prep)	Steel is Cleaned and Etched to Ensure Smooth, High Bond Paint Adhesion.
CROSSMEMBERS	3" x 2" x 3/16" Angle	FINISH	Painted with High-Solids Supreme Automotive Grade Enamel and Pin-Striped for a Highly Decorative and Protective Finish.
UPRIGHTS	14" Tall 2" x 2" x 1/8" Angle		
FENDERS	9" x 72" Rolled Formed w/Back		

Standard Features

- Safety Chains Attached w/Cold Rolled Eyelets
- Sand Foot on Jack
- Lower Jack Support Plate
- Floor Secured w/Torx Screws
- 4 Tie Down Loops
- Cambered EZ Lube Axles
- Two 3,500# Axles w/1 Electric Brake
- Complete Break-A-Way System with Charger

Dimensions			
Length	A	B	C
14'	169-1/2"	103"	66-1/2"
16'	193-1/2"	115"	78-1/2"

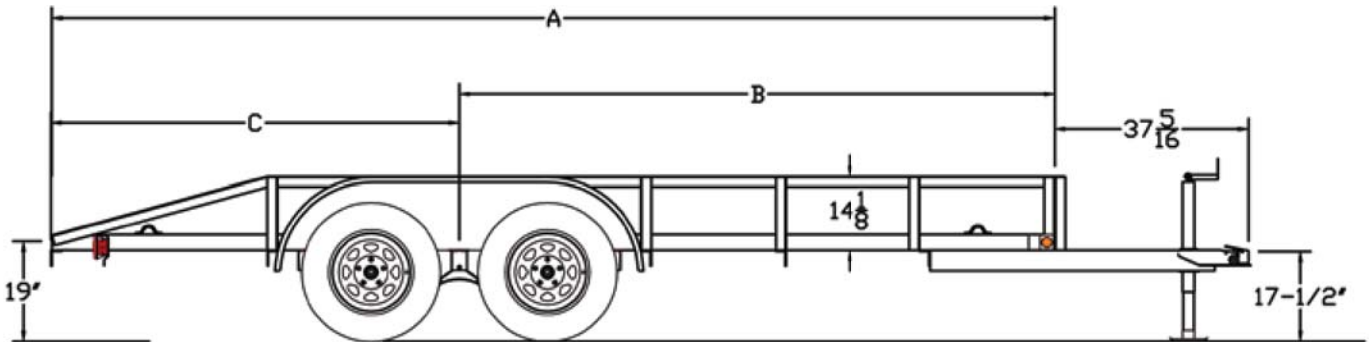

MODEL#	WEIGHT	DESCRIPTION
40SP-14	1,300#	77" x 14' Tandem Axle Trailer
40SP-16	1,430#	77" x 16' Tandem Axle Trailer

OPTIONS

Electric Brakes on 2nd Axle	15" Spare Tire (ST205/75-15 LR-C)
Spare Tire Mount (Side)	