

35SA-RS/R SX Single Axle Utility

G.V.W.R.	2,995#	AXLE	3,500# EZ Lube w/Brake Flanges
G.A.W.R.	2,995#	SUSPENSION	Multi-Leaf Spring
COUPLER	2" A-Frame	TIRE	ST205/75-15 Load Range C
SAFETY CHAINS	1/4" Grd. 30 w/Safety Latch Hook (2 each)	WHEEL	15 x 5 White Spoke 5 Bolt
JACK	2,000# Top Wind (Bolted On)	FLOOR	2" Pine
TONGUE	3" Channel Tongue	LIGHTS	D.O.T. Stop, Tail, Turn & Clearance
TOP RAIL	2" Square Tubing Top Rail	ELEC. PLUG	4-Way Flat w/Loom
FRAME	4" x 3" x 1/4" Angle	FINISH (Prep)	Steel is Cleaned to Ensure a Professional Smooth Finish.
CROSSMEMBERS	3" x 2" x 3/16" Angle	FINISH	Superior Quality Finish is Applied with Pin-Stripping for a Highly Decorative and Protective Finish.
UPRIGHTS	14" Tall, 2" x 2" x 1/8" Angle		
FENDERS	9" x 32" Rolled Formed w/Back		

Standard Features

- Safety Chains Attached w/Cold Rolled Eyelets
- Sand Foot on Jack
- Lower Jack Support Plate
- 2" Square Tubing Top Rail
- 6 Tie Down Loops
- EZ Lube Axle
- Flanges for Easy Brake Addition
- 2-5' Square Tubing Ramps (16" Wide) that can be used on either Side and on Rear
- Spare Tire Mount
- Rear Tail Board Channels
- Grommet Mount Sealed Lighting

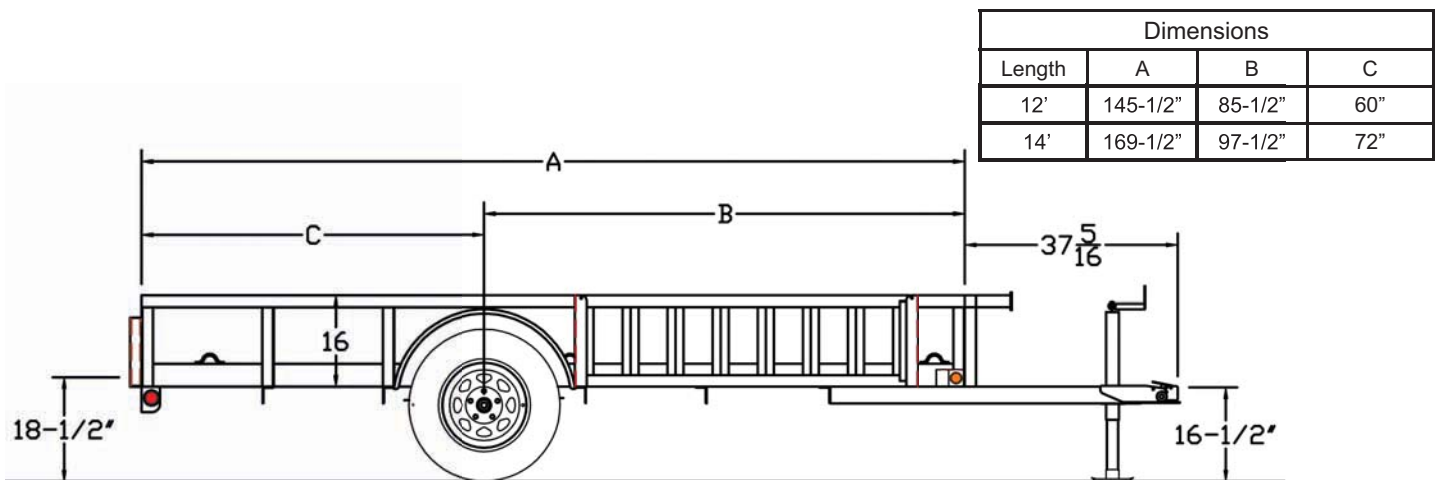

MODEL#	WEIGHT	DESCRIPTION
35SA-12RS	1,100#	77" x 12' Single Axle
35SA-12RSX	1,140#	83" x 12' Single Axle
35SA-14RS	1,230#	77" x 14' Single Axle
35SA-14RSX	1,270#	83" x 14' Single Axle

OPTIONS

2" Forged Coupler	Spare Tire (ST205/75-15 LR-C)
2K Fold-Up Jack	4' Rampgate (6.5W)
Electric Brakes w/Complete Break-Away Kit	4' Rampgate (7W)

STANDARD MODEL - NO OTHER OPTIONS AVAILABLE