

30SA / 35SA Single Axle Utility

G.V.W.R.	2,995#	AXLE	3,500# EZ Lube w/Brake Flanges
G.A.W.R.	2,995#	SUSPENSION	Multi-Leaf Spring
COUPLER	2" A-Frame	TIRE	ST205/75-15 Load Range C
SAFETY CHAINS	1/4" Grd. 30 w/Safety Latch Hook (2 each)	WHEEL	15 x 5 White Spoke 5 Bolt
JACK	2,000# Top Wind (Bolted On)	FLOOR	2" Pine
TONGUE	3" Channel	LIGHTS	D.O.T. Stop, Tail, Turn & Clearance
TOP RAIL	2-3/8" Pipe	ELEC. PLUG	4-Way Flat w/Loom
FRAME	3" x 2" x 3/16" Angle	FINISH (Prep)	Steel is Cleaned and Etched to Ensure Smooth, High Bond Paint Adhesion.
CROSSMEMBERS	3" x 2" x 3/16" Angle	FINISH	Painted with High-Solids Supreme Automotive Grade Enamel and Pin-Striped for a Highly Decorative and Protective Finish.
UPRIGHTS	15" Tall 2" x 2" x 1/8" Angle		
FENDERS	9" x 32" Rolled Formed w/Back		

Standard Features

- Safety Chains Attached w/Cold Rolled Eyelets
- Sand Foot on Jack
- Lower Jack Support Plate
- 3,500# Idler Axle w/Flanges for Easy Brake Addition
- 2-3/8" Pipe Top Rail
- 4 Tie Down Loops
- EZ Lube Axle
- Grommet Mount Sealed Lighting

Shown with Optional Gate

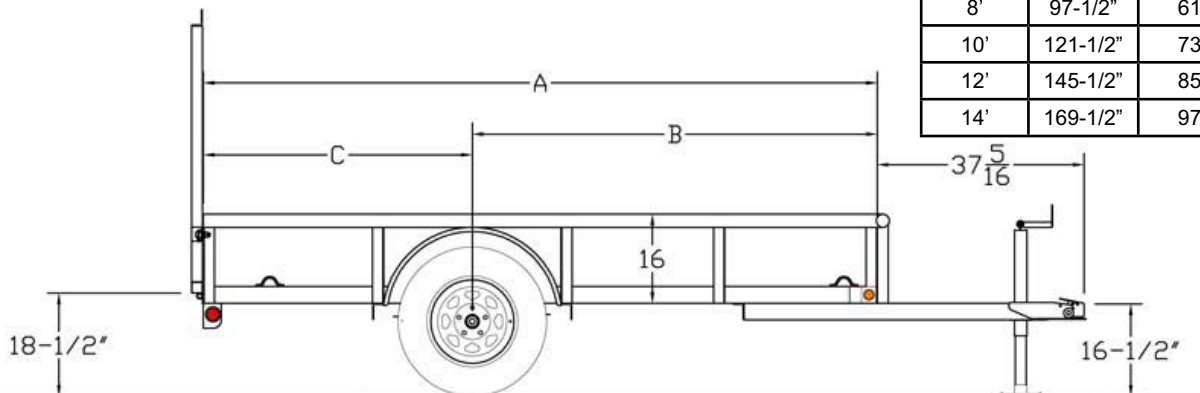

Dimensions			
Length	A	B	C
8'	97-1/2"	61"	36-1/2"
10'	121-1/2"	73"	48-1/2"
12'	145-1/2"	85"	60-1/2"
14'	169-1/2"	97"	72-1/2"

MODEL#	WEIGHT	DESCRIPTION
30SA-08	690#	60" x 8' Single Axle
30SA-10	710#	60" x 10' Single Axle
30SA-12	910#	60" x 12' Single Axle
30SA-14	990#	60" x 14' Single Axle
35SA-10	910#	77" x 10' Single Axle
35SA-12	1,020#	77" x 12' Single Axle
35SA-14	1,110#	77" x 14' Single Axle

OPTIONS

2" Forged Coupler	Spare Tire (ST205/75-15 LR-C)
2K Fold-Up Jack	4' Rampgate 5W - 3 Center Uprights
Set Back Jack	4' Rampgate 6.5 W - 4 Center Uprights
V Tongue Tilt	Gas Spring Assist Option - Rampgate
Electric Brakes w/Complete Break-Away Kit	Car Hauler Style
Spare Tire Mount (Side)	Tie Down Pockets (Each)
	4' Slide In Ramps (35SA Only)