

30AA / 35AA Single Axle All-Around

G.V.W.R.	2,995#	AXLE	3,500# EZ Lube w/Brake Flanges
G.A.W.R.	2,995#	SUSPENSION	Multi-Leaf Spring
COUPLER	2" A-Frame	TIRE	ST205/75-15 Load Range C
SAFETY CHAINS	1/4" Grd. 30 w/Safety Latch Hook (2 each)	WHEEL	15 x 5 White Spoke 5 Bolt
JACK	2,000# Top Wind (Bolted On)	FLOOR	2" Pine
TONGUE	3" Channel	LIGHTS	D.O.T. Stop, Tail, Turn & Clearance
SIDES	14" Solid Formed (14 Ga.) Side Panels w/2" Lip	ELEC. PLUG	4-Way Flat w/Loom
FRAME	3" x 2" x 3/16" Angle	FINISH (Prep)	Steel is Cleaned and Etched to Ensure Smooth, High Bond Paint Adhesion.
CROSSMEMBERS	3" x 2" x 3/16" Angle	FINISH	Painted with High-Solids Supreme Automotive Grade Enamel and Pin-Striped for a Highly Decorative and Protective Finish.
UPRIGHTS			
FENDERS	9" x 32" Rolled Formed		

Standard Features

- Safety Chains Attached w/Cold Rolled Eyelets
- Sand Foot for Jack
- Lower Jack Support Plate
- 17-1/4" Solid Formed Sheet Sides
- Floor Secured w/Torx Screws
- 4 Tie Down Loops Inside
- EZ Lube Axle
- Grommet Mount Sealed Lighting

Shown with Optional Gate

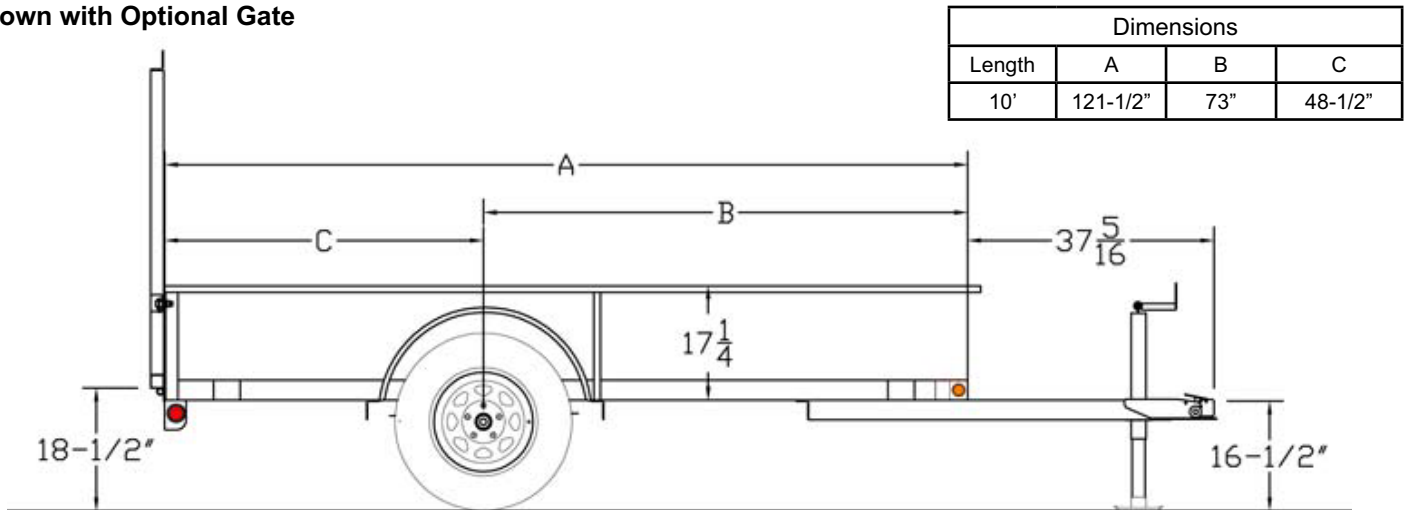

MODEL#	WEIGHT	DESCRIPTION
30AA-10	910#	60" x 10' Single Axle All Around
35AA-10	1,030#	77" x 10' Single Axle All Around

OPTIONS

2" Forged Coupler	Spare Tire (ST205/75-15 LR-C)
2K Fold-Up Jack	4' Rampgate 5 W - 3 Center Uprights
Set Back Jack	4' Rampgate 6.5 W - 4 Center Uprights
Electric Brakes w/Complete Break-Away Kit	Gas Spring Assist Option - Rampgate
Spare Tire Mount (Side)	

STANDARD MODEL - NO OTHER OPTIONS AVAILABLE