

# 29SA Single Axle Utility

<b>G.V.W.R.</b>	2,995#	<b>AXLE</b>	3,500# EZ Lube w/Brake Flanges
<b>G.A.W.R.</b>	2,960#	<b>SUSPENSION</b>	Multi-Leaf Spring
<b>COUPLER</b>	2" A-Frame	<b>TIRE</b>	ST205/75-15 Load Range B
<b>SAFETY CHAINS</b>	1/4" Grd. 30 w/Safety Latch Hook (2 each)	<b>WHEEL</b>	15 x 5 White Spoke 5 Bolt
<b>JACK</b>	2,000# Top Wind (Bolted On)	<b>FLOOR</b>	2" Pine
<b>TONGUE</b>	3" x 2" x 3/16" Angle	<b>LIGHTS</b>	D.O.T. Stop, Tail, Turn & Clearance
<b>TOP RAIL</b>	2" x 2" x 1/8" Angle	<b>ELEC. PLUG</b>	4-Way Flat w/Loom
<b>FRAME</b>	3" x 2" x 3/16" Angle	<b>FINISH (Prep)</b>	Steel is Cleaned and Etched to Ensure Smooth, High Bond Paint Adhesion.
<b>CROSSMEMBERS</b>	3" x 2" x 3/16" Angle	<b>FINISH</b>	Painted with High-Solids Supreme Automotive Grade Enamel and Pin-Striped for a Highly Decorative and Protective Finish.
<b>UPRIGHTS</b>	14" Tall, 2" x 2" x 1/8" Angle		
<b>FENDERS</b>	9" x 32" Rolled Formed w/Back		

## Standard Features

- Safety Chains Attached w/Cold Rolled Eyelets
- Sand Foot on Jack
- Lower Jack Support Plate
- Brake Flanges for Easy Brake Addition
- Floor Secured w/Torx Screws
- 4 Tie Down Loops Inside
- EZ Lube Axle
- Available in Black Only
- Available in 10' and 14' Only

Shown with Optional Gate

Dimensions			
Length	A	B	C
10'	121-1/2"	73"	48-1/2"
14'	169-1/2"	97"	72-1/2"

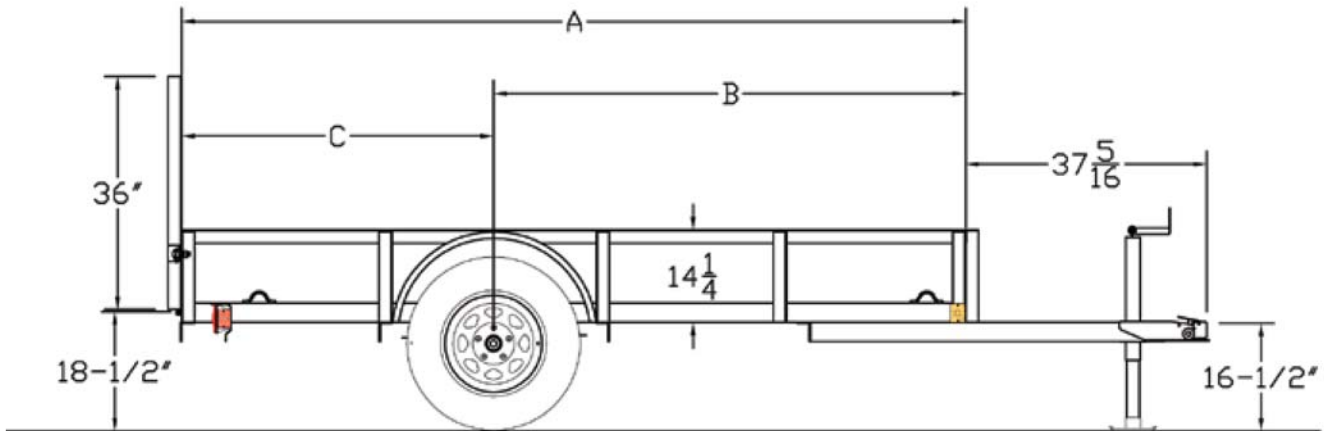

MODEL#	WEIGHT	DESCRIPTION
29SA-10	730#	60" x 10' Single Axle Trailer
29SA-14	940#	60" x 14' Single Axle Trailer

### OPTIONS

Spare Tire Mount	3' Rampgate w/Expanded Metal
15" Spare Tire & Wheel	

STANDARD MODEL - NO OTHER OPTIONS AVAILABLE