

# 19SV Single Axle Vanguard

<b>G.V.W.R.</b>	1,995#	<b>AXLE</b>	2,000# EZ Lube
<b>G.A.W.R.</b>	1,995#	<b>SUSPENSION</b>	Multi-Leaf Spring
<b>COUPLER</b>	2" A-Frame	<b>TIRE</b>	ST175/80-13" Load Range C
<b>SAFETY CHAINS</b>	1/4" Grd. 30 w/Safety Latch Hook (2 each)	<b>WHEEL</b>	13 x 4.5 White Spoke 5 Bolt
<b>JACK</b>	2,000# Top Wind (Bolted On)	<b>FLOOR</b>	2" Pine
<b>TONGUE</b>	3" Channel	<b>LIGHTS</b>	D.O.T. Stop, Tail, Turn & Clearance
<b>TOP RAIL</b>	1-5/8" Pipe	<b>ELEC. PLUG</b>	4-Way Flat w/Loom
<b>FRAME</b>	3" x 2" x 3/16" Angle	<b>FINISH (Prep)</b>	Steel is Cleaned to Ensure a Professional Smooth Finish.
<b>CROSSMEMBERS</b>	2" x 2" x 1/8" Angle	<b>FINISH</b>	Superior Quality Finish is Applied with Pin-Stripping for a Highly Decorative and Protective Finish.
<b>UPRIGHTS</b>	2" x 2" x 1/8" Angle		
<b>FENDERS</b>	8" x 28" Rolled Formed		

## Standard Features

- Safety Chains Attached w/Cold Rolled Eyelets
- Lower Jack Support Plate
- 4 Tie Down Loops Inside Bed
- Sand Foot on Jack
- 27-3/4" Sides w/ 24" V-Crimped Steel Panels
- EZ Lube Axle

### Shown with Optional Rampgate

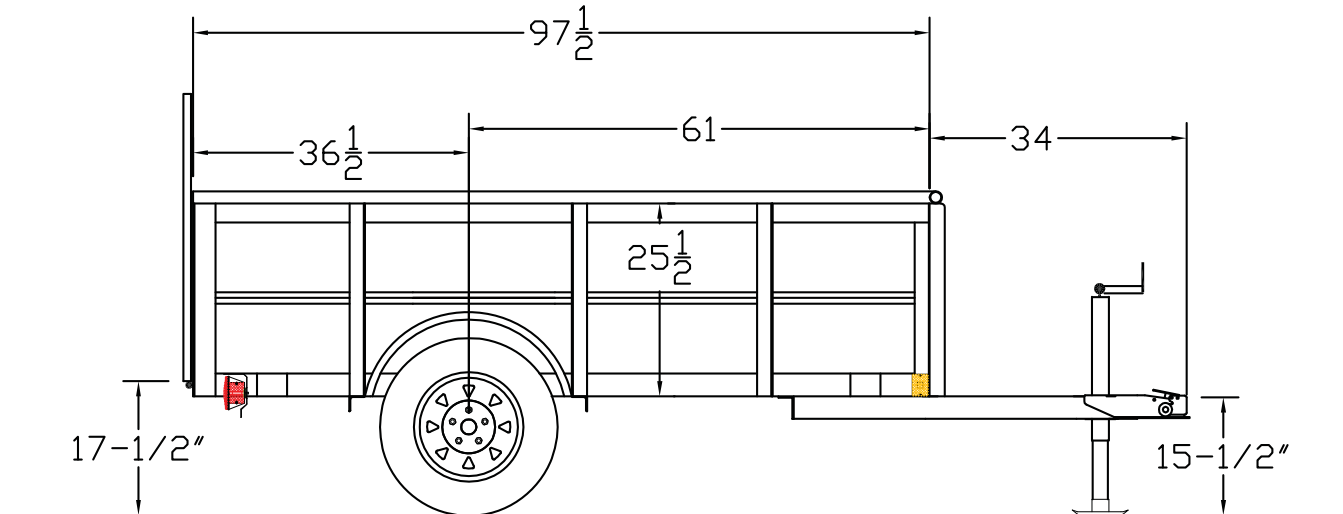

MODEL#	WEIGHT	DESCRIPTION
19SV-08	690#	50" x 8' Single Axle Vanguard

### OPTIONS

3' Rampgate w/Expanded Metal