

19SL Super Lil Tex Utility

G.V.W.R.	1,995#	AXLE	2,000# EZ Lube
G.A.W.R.	1,995#	SUSPENSION	Multi-Leaf Spring
COUPLER	2" A-Frame	TIRE	ST175/80-13" Load Range C
SAFETY CHAINS	1/4" Grd. 30 w/Safety Latch Hook (2 each)	WHEEL	13 x 4.5 White Spoke 5 Bolt
JACK	2,000# Top Wind (Bolted On)	FLOOR	2" Pine
TONGUE	3" Channel	LIGHTS	D.O.T. Stop, Tail, Turn & Clearance
TOP RAIL	2" x 2" x 1/8" Angle	ELEC. PLUG	4-Way Flat w/Loom
FRAME	3" x 2" x 3/16" Angle	FINISH (Prep)	Steel is Cleaned and Etched to Ensure Smooth, High Bond Paint Adhesion.
CROSSMEMBERS	3" x 2" x 3/16" Angle	FINISH	Painted with High-Solids Supreme Automotive Grade Enamel and Pin-Striped for a Highly Decorative and Protective Finish.
UPRIGHTS	11" Tall 2" x 2" x 1/8" Angle		
FENDERS	9" x 32" Square w/Backs		

Standard Features

- Safety Chains Attached w/Cold Rolled Eyelets
- Lower Jack Support Plate
- 4 Tie Downs
- Sand Foot on Jack
- Floor Secured w/Torx Screws
- EZ Lube Axle
- Flared Top Rail in Front for Extra Space

Shown with Optional Gate

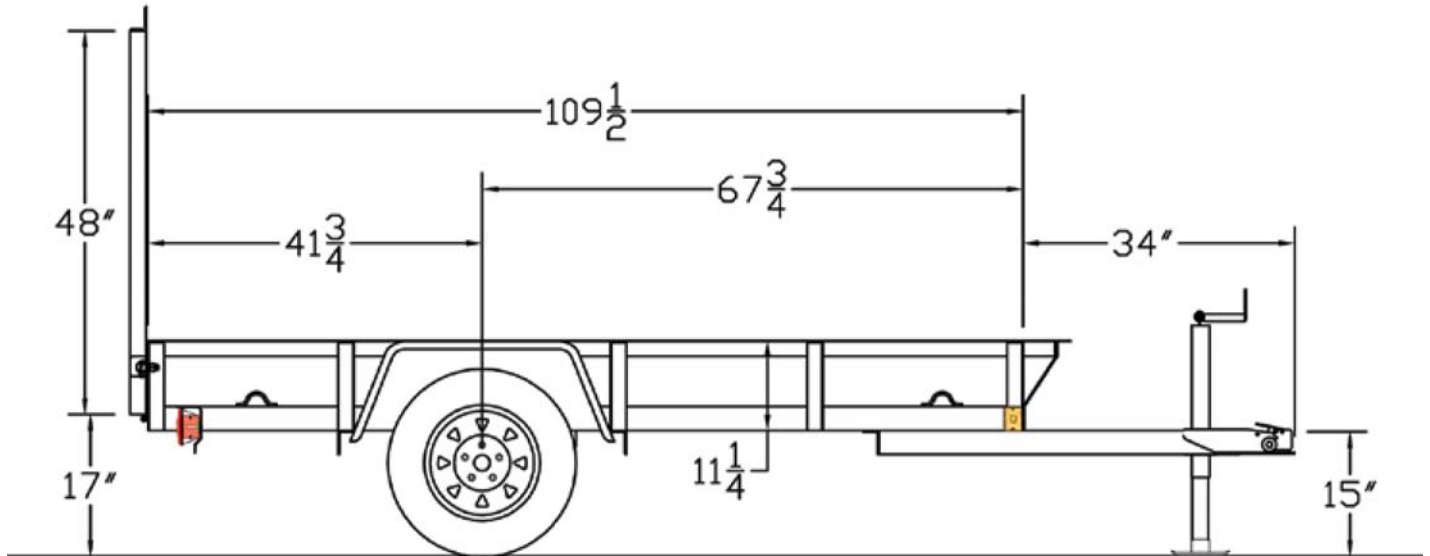

MODEL#	WEIGHT	DESCRIPTION
19SL-09	630#	54" x 9' Single Axle Trailer

OPTIONS

4' Rampgate w/Expanded Metal

STANDARD MODEL - NO OTHER OPTIONS AVAILABLE