

15MM Mini Tex Utility

G.V.W.R.	1,500#	AXLE	2,000# EZ Lube
G.A.W.R.	1,500#	SUSPENSION	Multi-Leaf Slipper Spring
COUPLER	2"	TIRE	4.80-12" Load Range C
SAFETY CHAINS	1/4" Grd. 30 w/Safety Latch Hook (2 each)	WHEEL	12 x 4 White Spoke 5 Bolt
JACK	None	FLOOR	2" Pine
TONGUE	Single 2" x 3" Tubing	LIGHTS	D.O.T. Stop, Tail, Turn & Clearance
TOP RAIL	None	ELEC. PLUG	4-Way Flat w/Loom
FRAME	3" Channel	FINISH (Prep)	Steel is Cleaned and Etched to Ensure Smooth, High Bond Paint Adhesion.
CROSSMEMBERS	2" x 2" x 1/8" Angle	FINISH	Painted with High-Solids Supreme Automotive Grade Enamel and Pin-Striped for a Highly Decorative and Protective Finish.
FENDERS	8" x 23" Square Type w/Backs		
SIDES	None		

Standard Features

- Safety Chains Attached w/Cold Rolled Eyelets
- Lower Tongue Support & Handle
- Car Hauler Style w/6 Stake Pockets
- Tubular Raised Tongue
- Floor Secured w /Torx Screws
- EZ Lube Axle

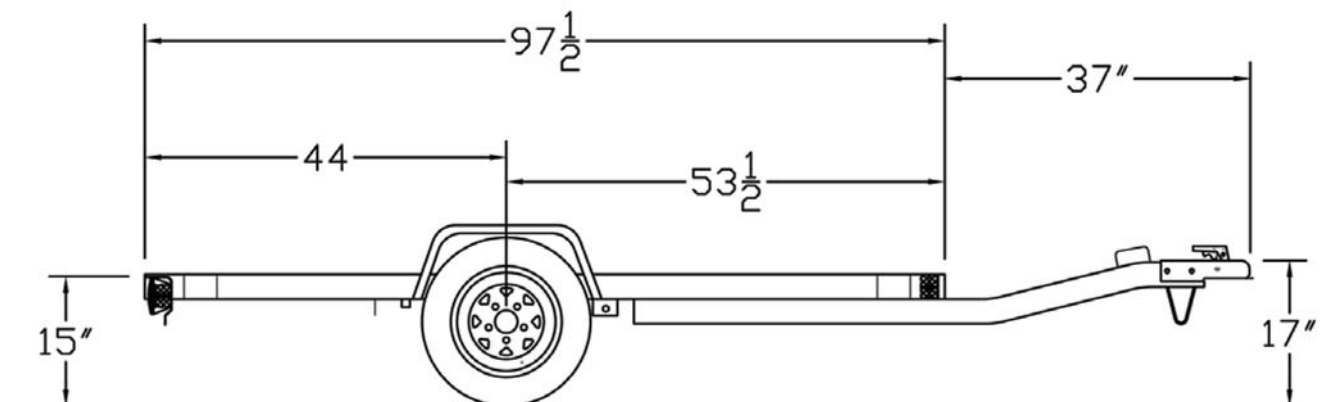

MODEL#	WEIGHT	DESCRIPTION
15MM-08	410#	50" x 8' Flat Bed, No Sides

OPTIONS

3' Rampgate w/Expanded Metal

STANDARD MODEL - NO OTHER OPTIONS AVAILABLE