

14CC Tandem Axle Equipment

G.V.W.R.	14,000#	AXLES	Two 7,000# EZ Lube w/Electric Brakes
G.A.W.R. (Ea. Axle)	7,000#	SUSPENSION	Multi-Leaf Spring w/Equalizer
COUPLER	Adjustable Cast 2-5/16"	TIRE	ST235/16 Load Range E
SAFETY CHAINS	3/8" Grd. 70 w/Safety Latch Hook (2 each)	WHEEL	16 x 6 Heavy White Mod
JACK	10,000# Top Wind Drop Leg (Bolted On)	FLOOR	2" Pine
TONGUE	6" Channel Fold Back	LIGHTS	D.O.T. Stop, Tail, Turn & Clearance
TOP RAIL	None	ELEC. PLUG	7-Way RV
FRAME	6" Channel	FINISH (Prep)	Steel is Cleaned and Etched to Ensure Smooth, High Bond Paint Adhesion.
CROSSMEMBERS	3" Channel	FINISH	Painted with High-Solids Supreme Automotive Grade Enamel and Pin-Striped for a Highly Decorative and Protective Finish.
UPRIGHTS	None		
FENDERS	9" x 72" Diamond Plate w/Back		

Standard Features

- 14K Adjustable Cast Coupler
- Safety Chains Attached w/Cold Rolled Eyelets
- Fold Back Tongue
- 2" Tubular Stop Rail
- Tie Down Pockets, Sides & Rear
- Floor Secured w/Torx Screws
- Reflective Marker Tape
- Cambered EZ Lube Axles
- Two 7,000# Axles w/Electric Brakes
- Complete Break-A-Way System w/Charger
- Spare Tire Mount
- Grommet Mount Sealed Lighting

Shown with Optional Slide In Ramps

Dimensions			
Length	A	B	C
16'	193-1/2"	111"	82-1/2"
18'	217-1/2"	127"	90-1/2"

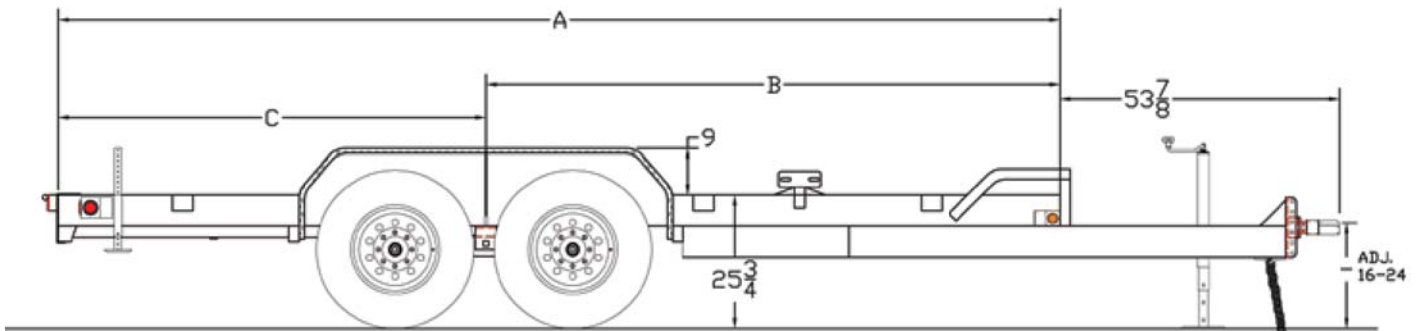

MODEL#	WEIGHT	DESCRIPTION
14CC-16	2,560#	83" x 16' Tandem Axle Equipment Trailer
14CC-18	2,710#	83" x 18' Tandem Axle Equipment Trailer

OPTIONS

Spare Tire (ST235/16 LR-E)	5' Slide in Ramps with Rear Stabilizer Stands
Spare Tire Mount	5' Stand up Ramps

STANDARD MODEL - NO OTHER OPTIONS AVAILABLE