

PRO SERIES TILT BED EQUIPMENT TRAILER

G.V.W.R.	12,000#	AXLES	Two 6000# EZ LUBE w/ Elec. Brakes
G.A.W.R. (EA. AXLE)	5,560#	SUSPENSION	Multi-Leaf Slipper Spring w/ Equalizer
COUPLER	2-5/16" Bulldog	TIRE	7.50 X 16" Load Range E
SAFETY CHAINS	1/4" Grd. 70 w/ Safety Latch Hook (2 ea.)	WHEEL	16 X 6 White Spoke 8 Bolt
JACK	2,000# Top Wind (Bolted On)	FLOOR	2" Pine
TONGUE	5" Channel Fold Back	LIGHTS	D.O.T. Stop, Tail, Turn and Clearance
TOP RAIL	(none)	ELEC. PLUG	7-Way RV
FRAME	6" Channel	FINISH (PREP)	Acid Etched w/White Phosphorus, Undercoated w/Panther 813 & Two Coats Primer
CROSSMEMBERS	3" Channel / 3" Sq. Tube	FINISH	Painted w/ 2 Coats High Solid <i>Supreme</i> Acrylic Automotive Grade Enamel, and Pinstriped
UPRIGHTS	(none)		
FENDERS	10 3/4" X 72" Diamond Plate Teardrop w/		

- Lower Jack Support Plate
- Two 6,000# Axles w/ 2 Electric Brakes
- Complete Break-A-Way System w/ Charger
- Fold Back Tongue w/ Raised Coupler
- Cambered Ez Lube Axles
- 1/4" Diamond Plate Knife Edge
- 2-5/16" Bulldog Forged Coupler
- Safety Chains Attached w/ Cold Rolled Eyelets
- Unique Two Piece Main Frame
- Tilt Platform is 75" Wide
- Floor Secured w/ 5/16" Torx Screws
- Spare Tire Mount
- Hydraulic Dampening System
- 102" Wide Overall, 80" between the fenders

12TL-20

LENGTH	DIMENSIONS			
	A	B	C	D
20'	248"	120"	128"	200"

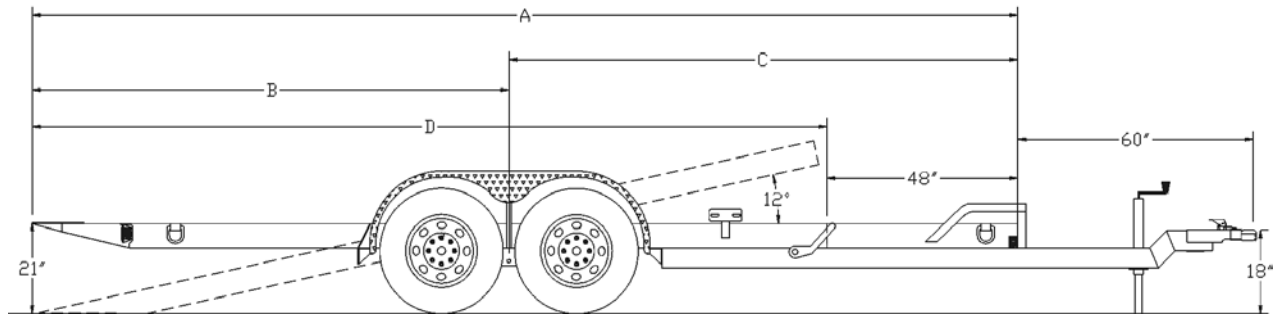

PRICING

MODEL #	WEIGHT	DESCRIPTION
12TL-20	3225#	80" X 20' (16' + 4') Tilt Trailer

OPTIONS

Hydraulic Brakes On 2 Axles w/ Adjustable Demco Actuator	
16" Spare Tire & Wheel	
1/8" Diamond Plate Steel Floor (Per Sq. Ft.)	
7K Drop-Leg Jack	
Adjustable Coupler In Channel	
Extra 5/8" D-Rings (Each)	
ST235-85R16 Tire Upgrade	
ST235-85R16 Spare	