

# 10FT Pro Series Tilt Bed Equipment

<b>G.V.W.R.</b>	9,990#	<b>AXLES</b>	Two 5,200# EZ Lube w/Electric Brakes
<b>G.A.W.R. (Ea. Axle)</b>	5,080#	<b>SUSPENSION</b>	Multi-Leaf Spring with Equalizer
<b>COUPLER</b>	Adjustable Forged 2-5/16"	<b>TIRE</b>	ST225/75-15 Load Range D
<b>SAFETY CHAINS</b>	1/4" Grd. 70 w/Safety Latch Hook (2 each)	<b>WHEEL</b>	15 x 6 White Spoke 6-Bolt
<b>JACK</b>	7,000# Drop Leg Jack (Bolted On)	<b>FLOOR</b>	2" Pine
<b>TONGUE</b>	5" Channel Fold Back	<b>LIGHTS</b>	D.O.T. Stop, Tail, Turn & Clearance
<b>TOP RAIL</b>	None	<b>ELEC. PLUG</b>	7-Way RV
<b>FRAME</b>	6" Channel	<b>FINISH (Prep)</b>	Steel is Cleaned and Etched to Ensure Smooth, High Bond Paint Adhesion.
<b>CROSSMEMBERS</b>	3" Channel, 3" Sq. Tube	<b>FINISH</b>	Painted with High-Solids Supreme Automotive Grade Enamel and Pin-Striped for a Highly Decorative and Protective Finish.
<b>UPRIGHTS</b>	None		
<b>FENDERS</b>	10-3/4" x 72" Teardrop w/Back		

## Standard Features

- Adjustable Forged Coupler
- Fold Back Tongue w/Raised Coupler
- Safety Chains Attached w/Cold Rolled Eyelets
- 7K Drop Leg Jack (Bolted On)
- Lower Jack Support Plate
- Unique Two Piece Main Frame
- 102" Wide Overall, 80" Width Between Fenders
- Tilt Platform is 75" Wide
- Hydraulic Dampening System
- Reflective Marker Tape
- Cambered EZ Lube Axles
- Two 5,200# Axles w/2 Electric Brakes
- Complete Break-A-Way System w/Charger
- Spare Tire Mount
- 1/4" Diamond Plate Knife Edge
- Grommet Mount Sealed Lighting

Dimensions				
Length	A	B	C	D
16'	202-1/2"	101"	101-1/2"	13°
18'	225-1/2"	113"	112-1/2"	12°
20'	249-1/2"	128"	121-1/2"	11°

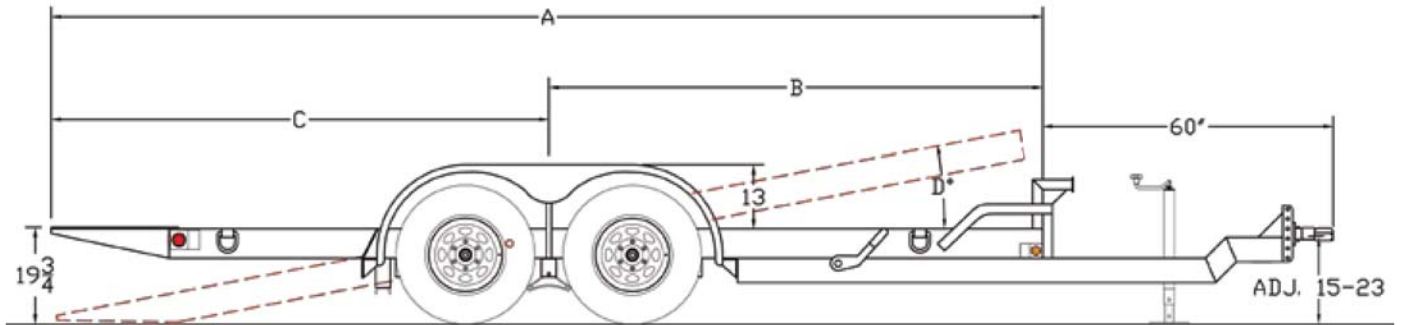

MODEL#	WEIGHT	DESCRIPTION
10FT-16	2,850#	80" x 16' Tilt Trailer
10FT-18	3,070#	80" x 18' Tilt Trailer
10FT-20	3,120#	80" x 20' Tilt Trailer

### OPTIONS

Adjustable Pintle in Channel	Tire Upgrade (7.50 x 16" LT LR-E)
Hydraulic Brakes 2 Axles	Spare Tire Upgrade (7.50 x 16" LT LR-E)
Spare Tire (ST225/75-15 LR-D)	