

10EP Tandem Axle Pan Equipment Transport

G.V.W.R. 9,990#	AXLES Two 5,200# EZ Lube Torflex Electric Brake
G.A.W.R. (Ea. Axle) 5,080#	SUSPENSION Torsion
COUPLER Adjustable Forged 2-5/16"	TIRE ST225/75D15 - Load Range D
SAFETY CHAINS 1/4" Grd. 70 w/Safety Latch Hook (2 each)	WHEEL 15 x 6 White Spoke 6 Bolt
JACK 2,000# Swivel Mount	LIGHTS D.O.T. Stop, Tail, Turn & Clearance
TONGUE 4" x 2" Square Tubing	ELEC. PLUG 7-Way RV
BED 3/16" Steel Pan	FINISH (Prep) Steel is Cleaned and Etched to Ensure Smooth, High Bond Paint Adhesion.
CROSSMEMBERS 3" Channel	FINISH Painted with High-Solids Supreme Automotive Grade Enamel and Pin-Striped for a Highly Decorative and Protective Finish.
FENDERS 10 x 72 Square Broke w/Teardrop	

Standard Features

- Fold Up Jack
- Safety Chains Attchd w/Cold Rolled Eyelets
- Safety Reflective Marker Tape
- 1 Piece 3/16" Formed Pan
- Texturized Floor for Increased Traction
- 78" Inside Dimension
- Six D-Rings (Inside Pan)
- Two 5,200# Axles w/Electric Brakes
- Cambered EZ Lube Axles
- Complete Break-A-Way System w/Battery & Charger
- 40" Heavy Duty Fold Up Ramps w/Expanded Metal
- Grommet Mount Sealed Lighting

Dimensions With Dovetail			
Length	A	B	C
14'	168"	102"	66"
16'	192"	144"	78"

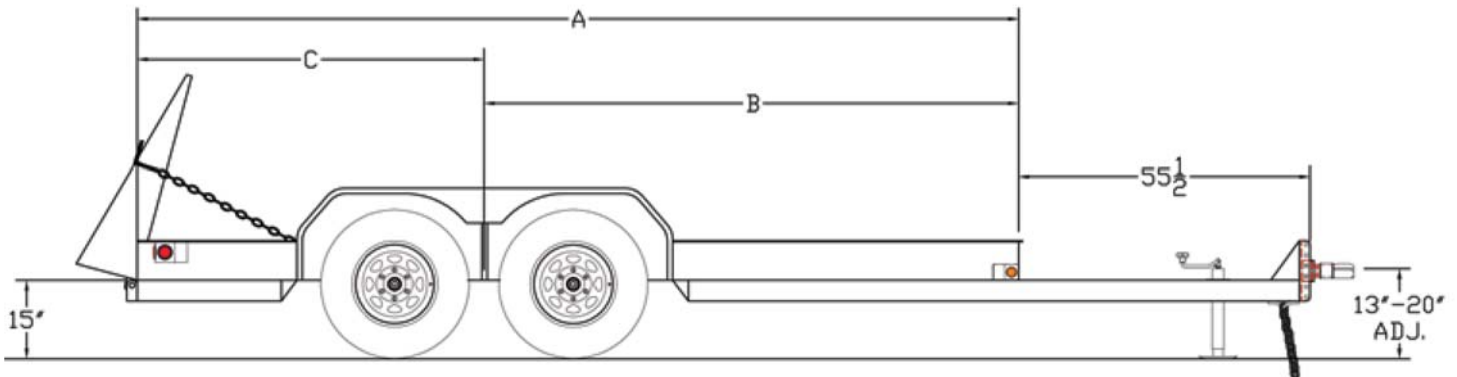

MODEL#	WEIGHT	DESCRIPTION
10EP-14	2,400#	78" x 14' Equipment Transport
10EP-16	2,500#	78" x 16' Equipment Transport

OPTIONS

Adjustable 3" Pintle	Spare Tire (ST225/75-15 LR-D)
Hydraulic Surge Brakes on Both Axles	Tire Upgrade (7.50 x 16" LT LR-E)
Spare Tire Mount	Spare Tire Upgrade (7.50 x 16" LT LR-E)