

10CC Tandem Axle Equipment

G.V.W.R.	9,990#	AXLES	Two 5,200# EZ Lube w/Electric Brakes
G.A.W.R. (Ea. Axle)	5,080#	SUSPENSION	Multi-Leaf Spring w/Equalizer
COUPLER	Adjustable Forged 2-5/16"	TIRE	ST225/75-15 Load Range D
SAFETY CHAINS	1/4" Grd. 70 w/Safety Latch Hook (2 each)	WHEEL	15 x 6 White Spoke 6 Bolt
JACK	7,000# Top Wind Drop Leg (Bolted On)	FLOOR	2" Pine
TONGUE	5" Channel Fold Back	LIGHTS	D.O.T. Stop, Tail, Turn & Clearance
TOP RAIL	None	ELEC. PLUG	7-Way RV
FRAME	5" Channel	FINISH (Prep)	Steel is Cleaned and Etched to Ensure Smooth, High Bond Paint Adhesion.
CROSSMEMBERS	3" Channel	FINISH	Painted with High-Solids Supreme Automotive Grade Enamel and Pin-Striped for a Highly Decorative and Protective Finish.
UPRIGHTS	None		
FENDERS	9" x 72" Diamond Plate w/Back		

Standard Features

- Adjustable Forged Coupler
- Safety Chains Attached w/Cold Rolled Eyelets
- Fold Back Tongue
- 2" Tubular Stop Rail
- Tie Down Pockets - Sides & Rear
- Floor Secured w/Torx Screws
- Cambered EZ Lube Axles
- Two 5,200# Axles w/Electric Brakes
- Complete Break-A-Way System w/Charger
- Reflective Marker Tape
- Rear Stabilizer Stands with Slide In Ramps
- Grommet Mount Sealed Lighting

Shown with Optional Spare Mount and Slide In Ramps

Dimensions			
Length	A	B	C
16'	193-1/2"	111"	82-1/2"
18'	217-1/2"	127"	90-1/2"

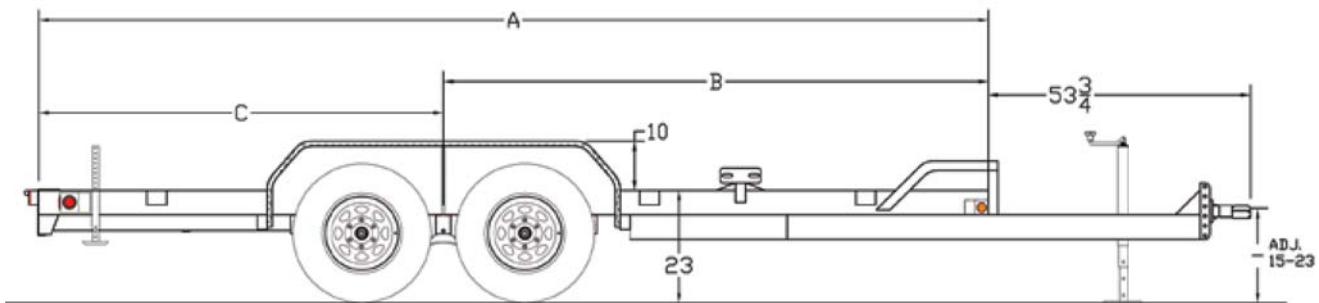

MODEL#	WEIGHT	DESCRIPTION
10CC-16	2,400#	83" x 16' Tandem Axle Equipment Trailer
10CC-18	2,440#	83" x 18' Tandem Axle Equipment Trailer

OPTIONS

Spare Tire (ST225/75-15 LR-D)	5' Rear Slide in Ramps
Spare Tire Mount	5' Stand up Ramps

STANDARD MODEL - NO OTHER OPTIONS AVAILABLE